

CNC-Shield V3 Datenblatt

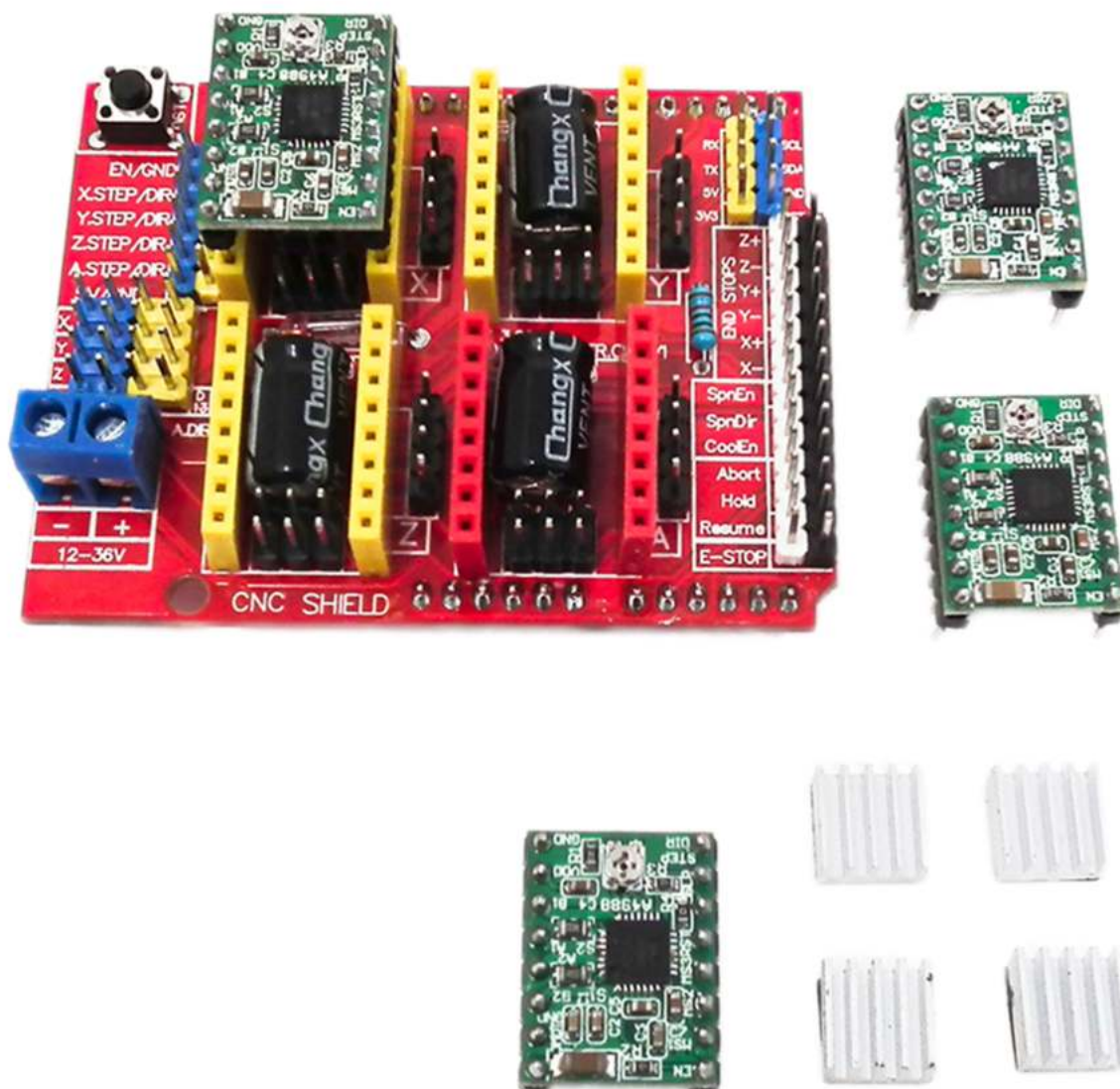

Contents:

- 1. Brief Data**
- 2. Configuring Micro Stepping for Each Axis**
- 3. Hooking Up the Stepper Motor to CNC Shield**

1. Brief Data

- GRBL 0.9 compatible. (Open source firmware that runs on an Arduino UNO that turns G-code commands into stepper signals)
- 4-Axis support (X, Y, Z, A-Can duplicate X,Y,Z or do a full 4th axis with custom firmware using pins D12 and D13)
- 2 x End stops for each axis (6 in total)
- Coolant enable
- Uses removable A4988 compatible stepper drivers. (A4988, DRV8825 and others) (Not Included)
- Jumpers to set the Micro-Stepping for the stepper drivers. (Some drivers like the DRV8825 can do up to 1/32 micro-stepping)
- Compact design.
- Stepper Motors can be connected with 4-pin Molex connectors or soldered in place.
- Runs on 12-36VDC. (At the moment only the DRV8825 drivers can handle up to 36V so please consider the operation voltage when powering the board.)

2. Configuring Micro Stepping for Each Axis

Each axis has 3 jumpers that can be set to configure the micro stepping for the A4988 plug-in driver board.

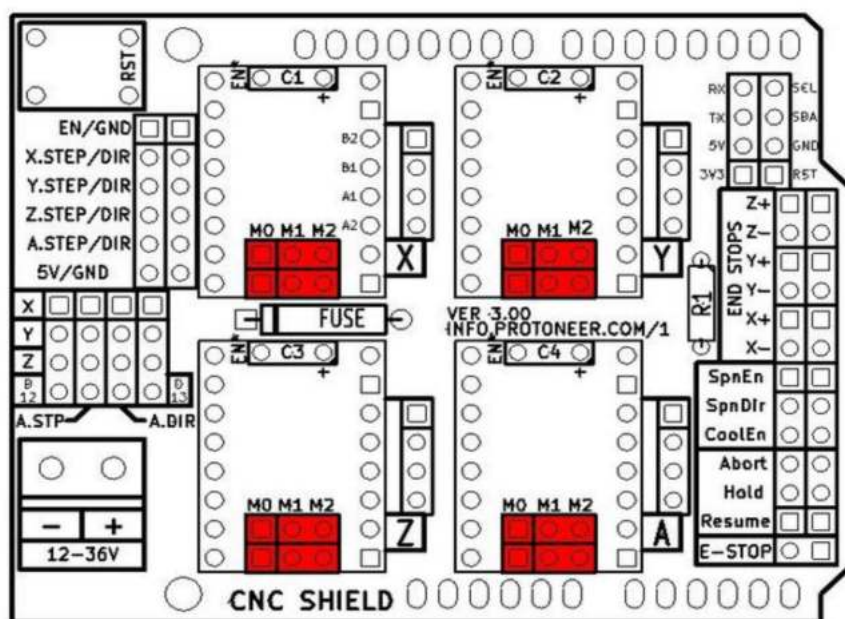

Micro-stepping jumper location, before inserting A4988.

In the tables below „High” indicates that a jumper is insert and „Low” indicates that no jumper is inserted.

MS0	MS1	MS2	Microstep Resolution
Low	Low	Low	Full Step
High	Low	Low	1/2 Step
Low	High	Low	1/4 Step
High	High	Low	1/8 Step
High	High	High	1/16 Step

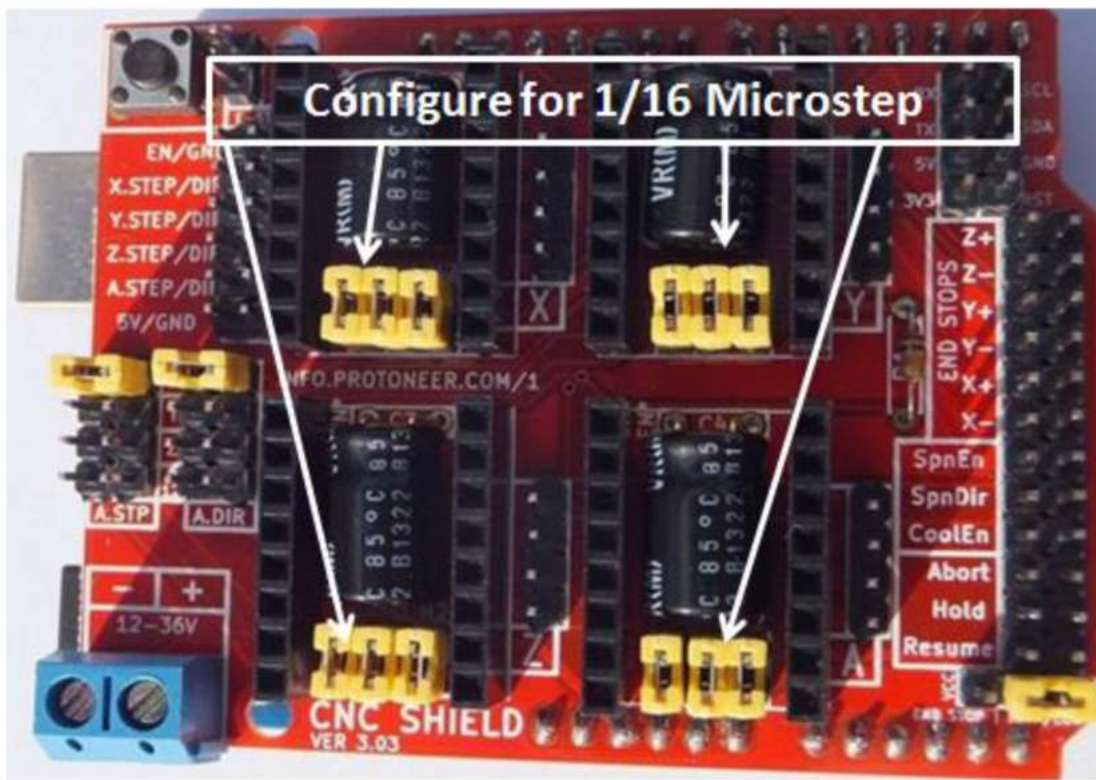

After setting the microstep jumper, you can plug-in A4988 driver boards as shown in the photo below. The photo also shown this CNC sit nicely on top of Arduino Uno board, without any external jumper wires.



!!! Beware of the orientation of the A4988 driver boards! You will destroy the A4988 driver board if plug-in with wrong orientation.

3. Hooking Up the Stepper Motor to CNC Shield

Connect steppers motor to CNC Shield board as the below block diagram. of the CNC Shield connected to 3-stepper motor:

